

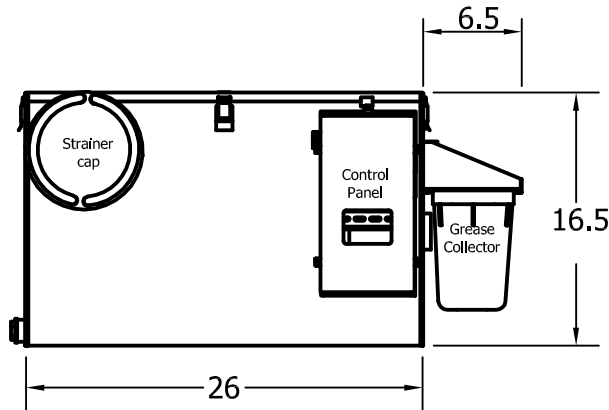

GGX25 Grease Guardian Standard Specification

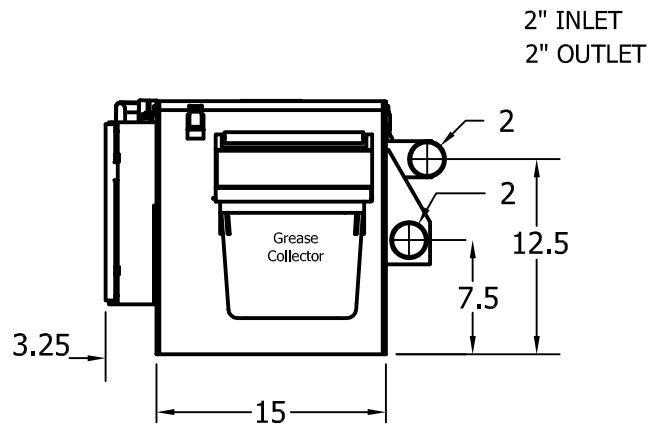

FRONT VIEW



END VIEW

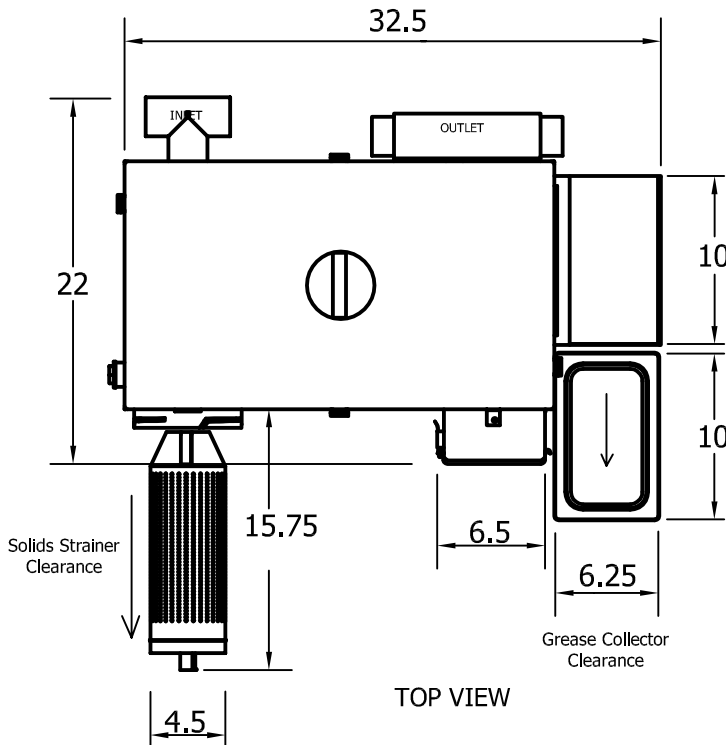

TOP VIEW

GREASE GUARDIAN STANDARD FEATURES:

- 3 Year Guarantee
- Fully Automatic Grease Removal Unit (AGRU)
- 16 gauge stainless steel welded tank
- Fully sealed air tight lid
- Universal flow direction
- PLC/HMI automatic controller
- Audible alerts
- Energy saving mode
- Long life skimmer blade
- Dry basket solids strainer
- Concealed plumbing & electrical connections
- No internal tank user maintenance required
- Grease Guardian World asset management

APPROVED SYSTEM



Product Acceptance Codes
Massachusetts Board of State Examiners
of Plumbers and Gas Fitters P1-0713-530,

TECHNICAL DATA

Weight _____	84 pounds
Material _____	16 Gauge Stainless Steel
Interior _____	Stainless Steel & Acetal Plastic Components
Maximum Flow Rate _____	25 gallons per minute
Tank Grease Retention Capacity _____	57.4 pounds (NSF Verified)
Solids Strainer Capacity _____	6.6 Pounds
Skimming Rate _____	11 pounds per hour
Programming/Control _____	7 day, 24hr Multifunctional
Electrical Load _____	110VAC 625watts 5.7A



GGX25 Grease Guardian Installation Details

KEY INSTALLATION NOTES:

- Allow for the minimum clearances shown
- For tank base allow at least 38.5" length x 22" width clearance.
- Allow adequate access to slide-in strainer & slide-in grease collector from front.
- Inlet port is both single/dual entry
- Outlet port is both single/dual entry.
- Keep outlet piping at $\frac{1}{8}$ " per foot fall or more.
- User rubber adjustable pipe connectors as supplied.
- Only switch on after filling system with water to static level.
- Refer to long manual for full installation.

Pre start up checks:

- Ensure unit is positioned on a level surface and is plumbed in securely.
- Ensure electrical outlet is fitted with dedicated ground fault circuit breaker.
- Ensure that the unit is filled with water to the correct level
- Ensure strainer basket is fully closed
- Set controller date and time as detailed in the manual
- Ensure that collection receptacle is empty and securely in place

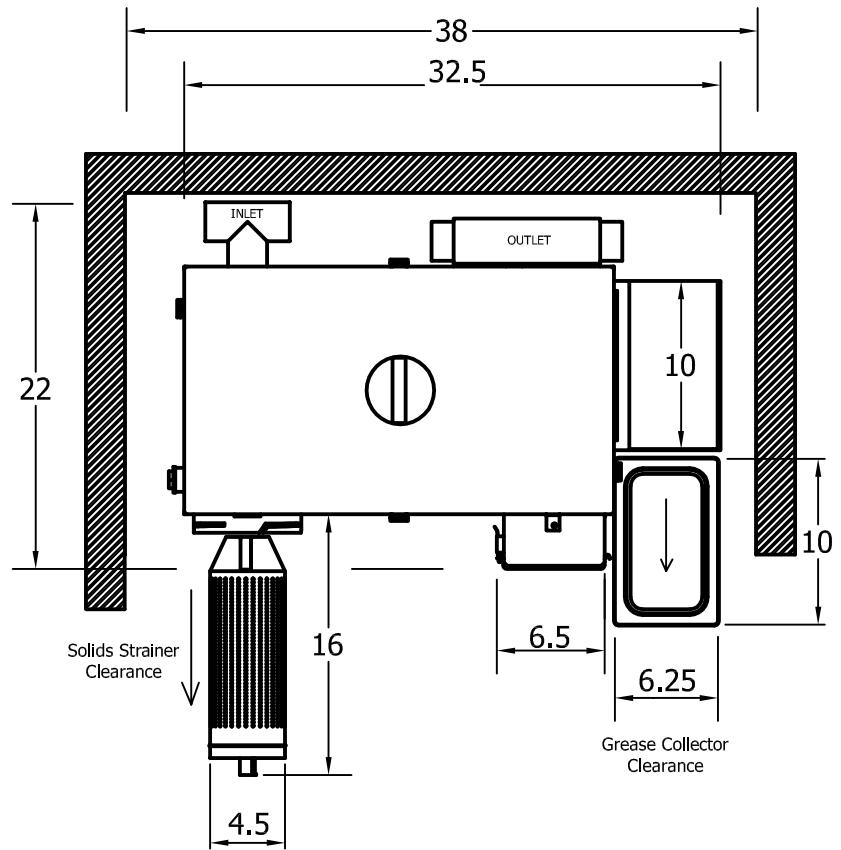

MINIMUM FLOOR SPACE RECOMMENDATION

Specification

Grease Guardian X series GGX25 automatic grease removal unit is a totally engineered system for separating free floating grease and oils from drain water flows and is rated at 25 gallons per minute.

The Grease Guardian GGX25 comprises of a 304 stainless steel welded tank with fully sealed removable stainless steel cylindrical solids basket, fully sealed 304 stainless steel lid, geared motor drive with overload protection, automatic grease removal roller assembly, self regulating immersion heater, integral gas trap, separated grease and oil container, digital PLC controller with HMI. The Grease Guardian GGX25 has been electrically tested and approved to UL499 standards and CSA C22-2 88-1952. 3 year warranty as standard.

Grease Guardian World asset management aftersales program is available to all Grease Guardian products.

Electrical Details

GGX25 110vac, 625watts, 5.7A

Grease Guardian World

Grease Guardian World is an interactive online register of all Grease Guardian branded products uploaded and managed by Grease Guardian, distributors and end users.

Grease Guardian World allows us to:

- Upload and manage individual sites
- Monitor specification, service history, supplier details for each Grease Guardian installed
- Upload and view installation photographs
- Upload and view Operation & Maintenance manuals
- Upload and view service engineer reports
- Locate sites using Google Maps linking
- Automatically remind distributors, customers and end users when service is due and warranties expire.
- Access and manage accounts on-line
- Manage recycled FOG

